



Screwdriving technology

Automation

Air motors

Air tools



DEPRAG

POWER LINE

high performance air motors
from 1.6 to 18 kW

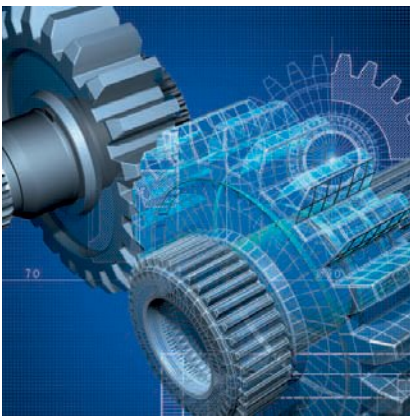

The high starting torque on this machine, its unrivalled light weight, as well as its robust and reliable design are clear advantages in comparison with any electric drive.

The product line of versatile high performance foot and flange motors is in a class of its own.

high performance
long life-span

robust
reliable

low weight
high starting torque



OVERVIEW PRODUCT SPECTRUM POWER LINE MOTORS

POWER LINE High performance motors



POWER LINE High performance motors with integrated planetary gears provide highest torque.

They are available in

- flange design (FM)
- foot design (KM)

Reversal via external valve

Performance classes:

1.6 kW	Page 28
2.6 kW	Page 28
3.6 kW	Page 28
5.1 kW	Page 32
9 kW	Page 32
18 kW	Page 32

Reversal via lever

Performance classes:

1.9 kW	Page 30
3.3 kW	Page 30
4.6 kW	Page 30

The Design of your Air Motor:

Calculating the motor performance:

$$P = \frac{M \times n}{9550}$$

P = Power Output in kW
M = Nominal Torque in Nm
n = Nominal-Speed in rpm

Power [HP] = P [kW] x 1.34
Torque [in.lbs] = M [Nm] x 8.85

The optimal working range of an air motor is close to the nominal speed.

If you require lower speeds than those mentioned in the catalogue then you can reduce the speed smoothly by throttling the exhaust air without significant loss of performance or torque.

By throttling the supply air or decreasing the operating pressure the speed, the torque and the performance of the motor can be reduced.

All performance data for DEPRAG air motors is based on operating pressure of 6 bar and the minimum allowable opening cross-section of the feed hose as stated in each motor's data.

If your surrounding conditions vary from this you will find a comprehensive guide to our motors in brochure D 6000 E. We will also be happy to answer any questions directly.

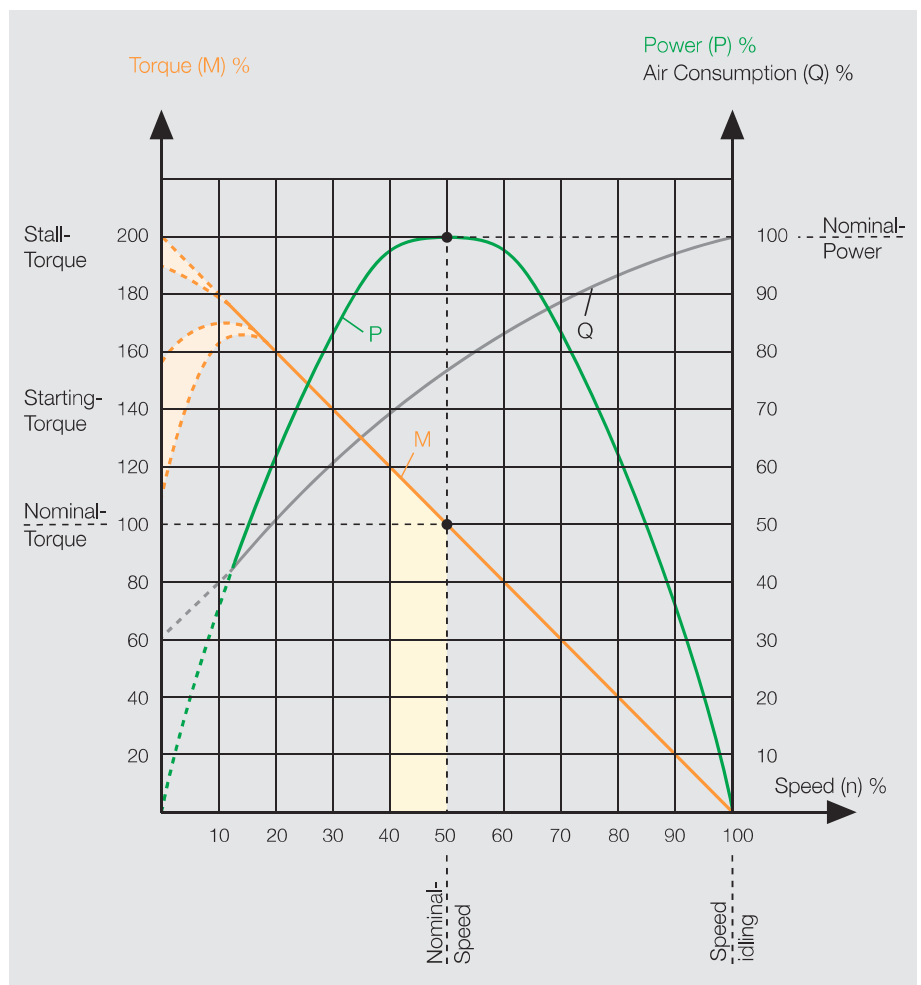

= optimal working range of the air motor

5.1 kW / 9 kW / 18 kW POWER LINE HIGH PERFORMANCE MOTORS

The motors in this design series can be operated in either right- or left rotation. Alternatively, the motor can also be reversed by two external 3/2-way valves or one 5/3-way valve (each with sufficiently large cross-sections).

Motor design Motor size		Bracket motor 54	Bracket motor 55		Flange motor 65
Motor, reversible by external valve	Type order no.	KM 54 LX7 *) 442397 D	KM55-16F1 442767 A	KM55-7F1 442767 B	FM 65 444200 A
Nominal-Power	kW / HP	5,1 / 6,8	9 / 12	9 / 12	18 / 24
Nominal-Speed	rpm	300	800	400	3000
Speed (idling)	rpm	600	1600	800	6000
Nominal-Torque	Nm / in.lbs	160 / 1416	107 / 947	215 / 1903	57 / 504
Start-Torque min.	Nm / in.lbs	240 / 2124	160 / 1416	320 / 2832	85 / 752
Air consumption	m ³ /min / cfm	6,2 / 219	10 / 353	10 / 353	20 / 706
Weight	kg / lbs	30 / 66	36 / 79	36 / 79	53 / 117
Hose I.D.	mm / in.	25 / 1	25 / 1	25 / 1	50 / 2

Performance data relate to an air pressure of 6 bar (85 PSI)

*) not reversible by external 3/2- or 5/3-way valve

Dimensions of motor (mm)

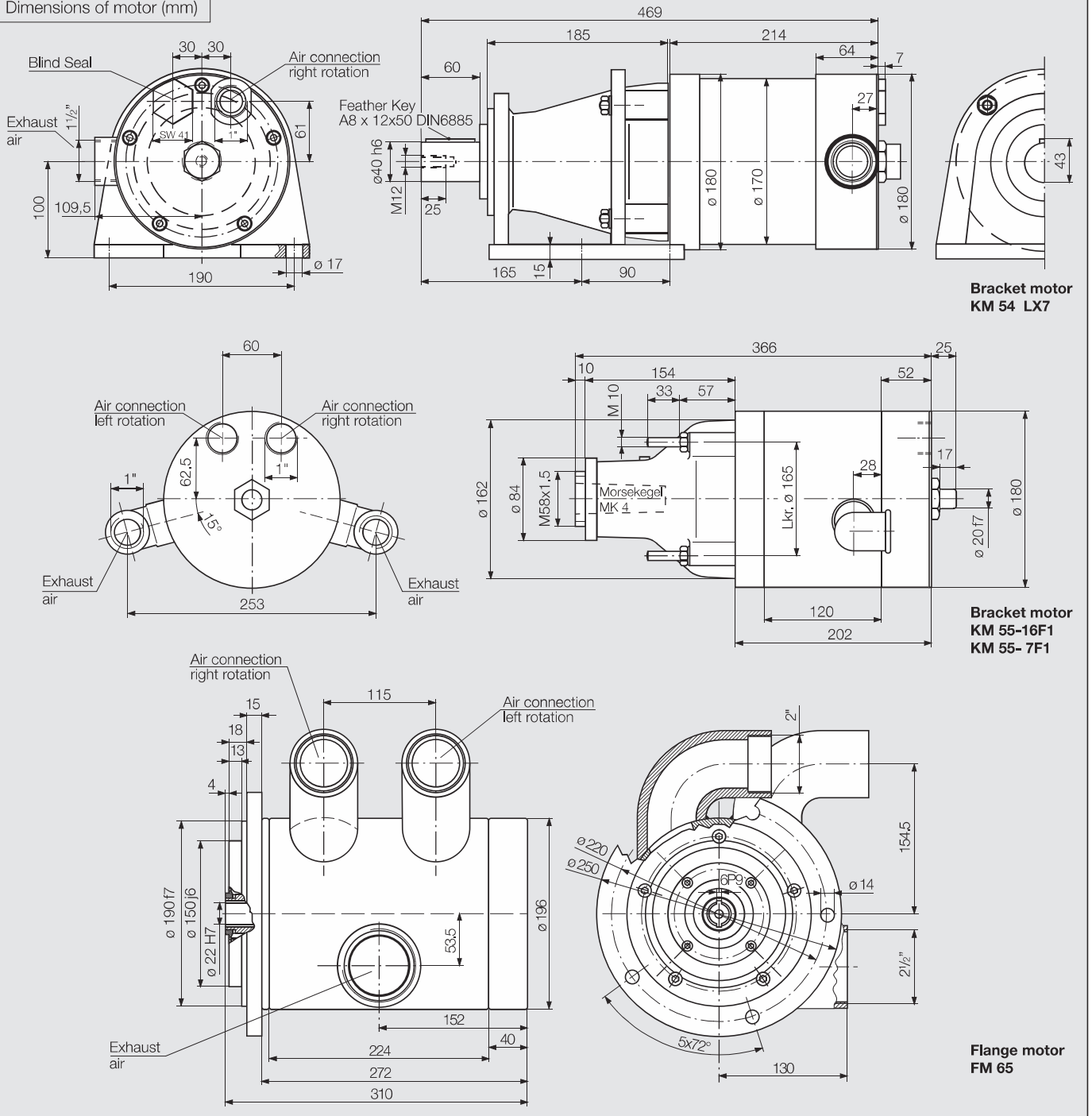

ACCESSORIES

Spare Parts Kit

Appropriate for each motor	Type	68-009	68-0011	68-0013
Spare Parts Kit	order no.	445033 A	445034 A	445035 A
Consisting of: Bearing, Vanes, Springs and Seal rings				

Silencer

Appropriate for each motor	Type	68-009	68-0011	68-0013
Silencer Set including connection	order no.	440021 A	440022 A	440023 A

Holding brake

Our holding brakes are designed for the motors 68-009, 68-0011 and 68-0013 and can be ordered fully mounted together with the motors.

In addition the holding brake is also suitable for upgrading the motor type 68-009. We can carry out this upgrade for you on request.

Appropriate for each motor	Type	68-009	68-0011	68-0013
Holding brake	order no.	445709 B	on request	on request
Brake-Torque		12 Nm*)	28 Nm*)	46 Nm*)

*) The holding brake is not designed for use with a different drive system. Please only use it in combination with the stated motor types.

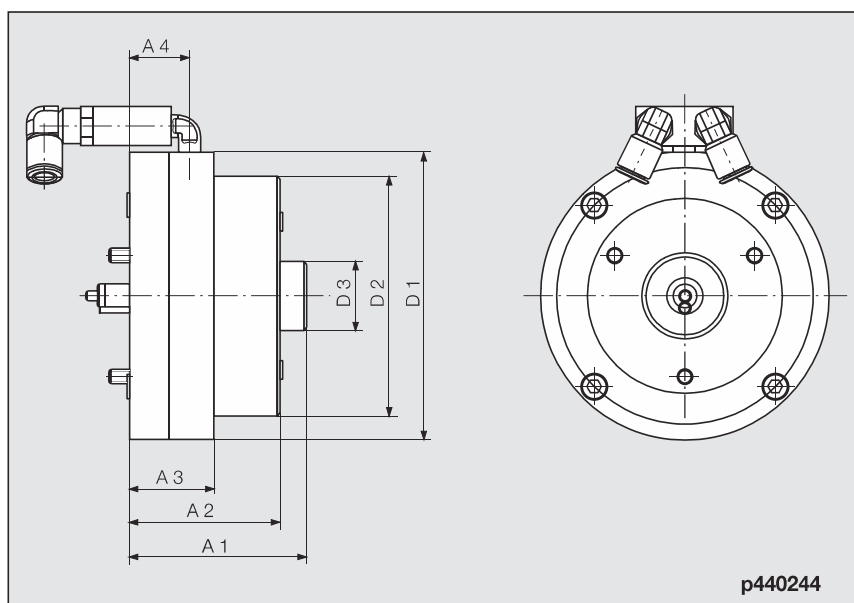

Type	Dimensions of braking device (mm)						
	A1	A2	A3	A4	D1	D2	D3
M9U	72,5	61,5	34,5	24,5	118	98	28
M11U	107	98	43,5	35,5	190	162	28
M13U							

ACCESSORIES

Maintenance Unit

Maintenance Unit consisting of filter, oiler and double nipple alternatively available with or without pressure regulator

Type of Motor	Thread Size	Air Flow	order no. without pressure regulator	order no. with pressure regulator
68-009	G 1	0.8 - 6 m ³ /min	821609 A	821179 A
68-0011	G 1	0.8 - 6 m ³ /min	821609 A	821179 A
68-0013	G 1 1/2	5 - 16 m ³ /min	805044 A	-
FM 32 / KM 32	G 1	0.8 - 6 m ³ /min	821609 A	821179 A
FM 50 / KM 50	G 1	0.8 - 6 m ³ /min	821609 A	821179 A
FM 52 / KM 52	G 1 1/2	5 - 16 m ³ /min	805044 A	-
KM 54	G 1 1/2	5 - 16 m ³ /min	805044 A	-
KM 55	G 1 1/2	5 - 16 m ³ /min	805044 A	-
FM 65	G 2	7 - 20 m ³ /min	350005 A	-

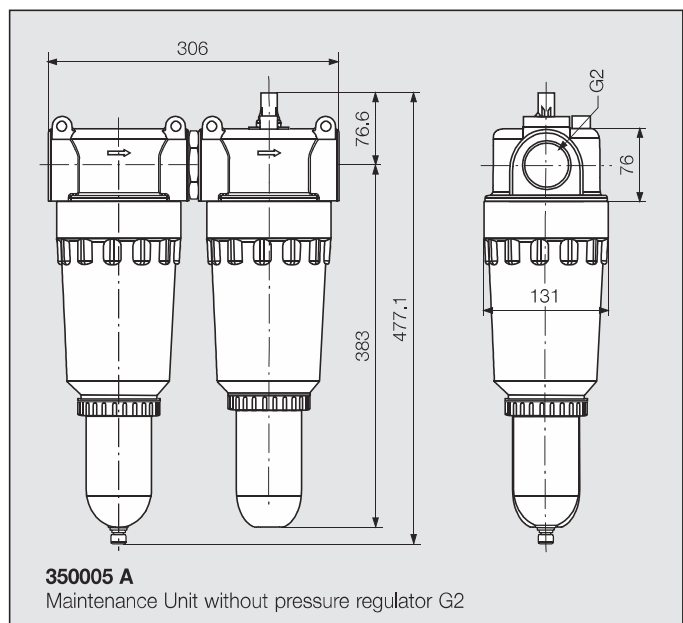
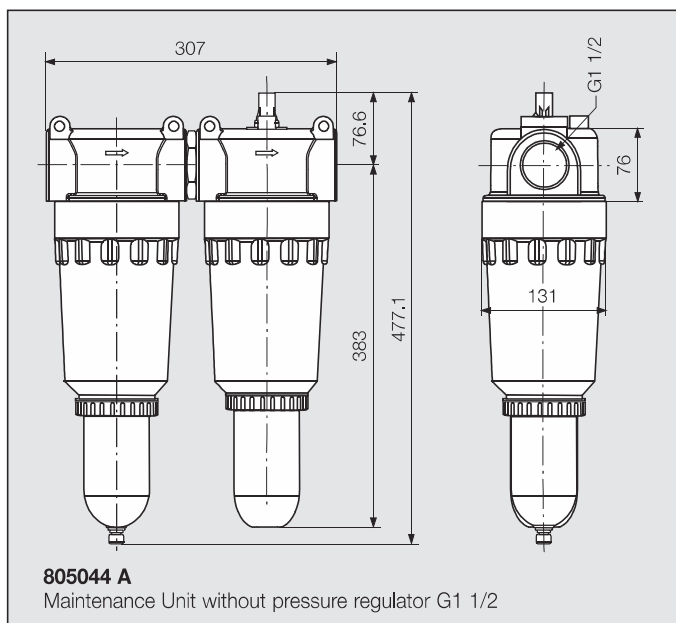
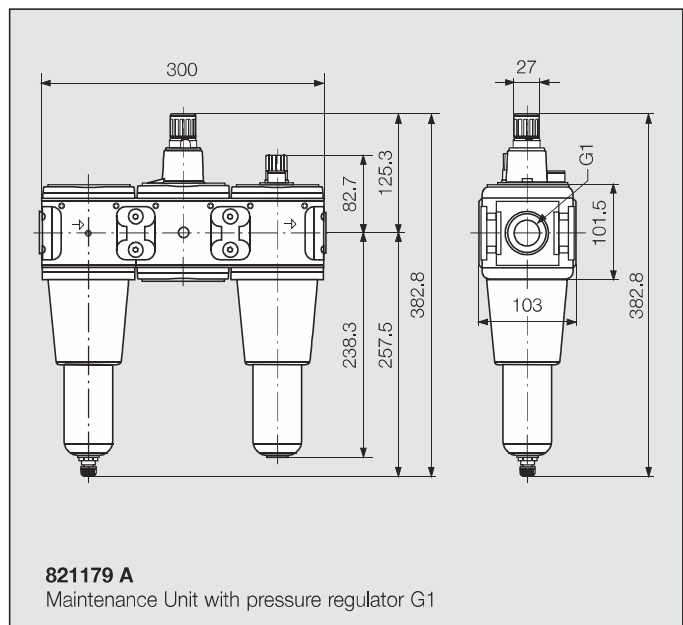
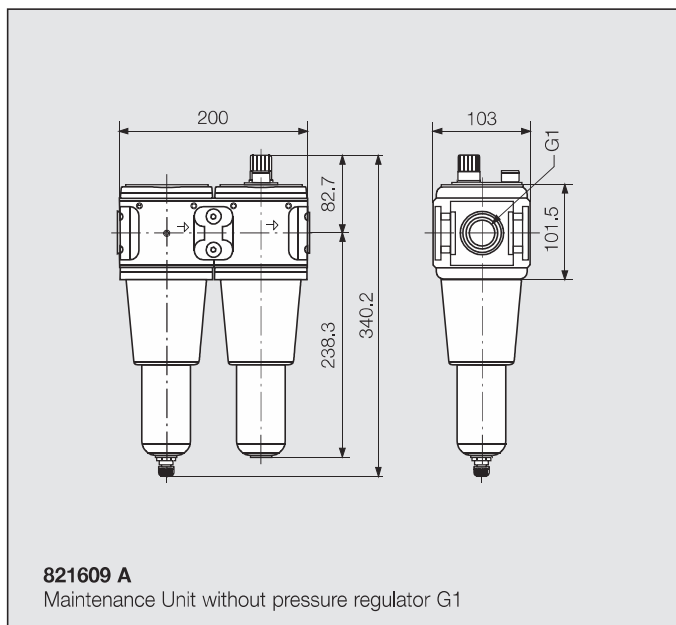

Do you need support in selecting the right drive system?

Tell us your operational conditions and our application consultants will be happy to help:

Application:	<input type="text"/>		
In what kind of environment will the motor be installed?	ATEX requirement / explosion safety?	<input type="checkbox"/> yes	<input type="checkbox"/> no
	if yes, which safety class:	<input type="text"/>	
	food industry conformity?	<input type="checkbox"/> yes	<input type="checkbox"/> no
	sterilisable?	<input type="checkbox"/> yes	<input type="checkbox"/> no
	acid resistant?	<input type="checkbox"/> yes	<input type="checkbox"/> no
	steam resistant?	<input type="checkbox"/> yes	<input type="checkbox"/> no
Application conditions:	constant operation (24 hrs, non-stop)	<input type="checkbox"/> yes	<input type="checkbox"/> no
	duty cycle in hrs/day:	<input type="text"/>	
	days/year:	<input type="text"/>	
	cycle time (s):	<input type="text"/>	
	motor loaded to stall?	<input type="checkbox"/> yes	<input type="checkbox"/> no
	self-locking?	<input type="checkbox"/> yes	<input type="checkbox"/> no
Required turn direction:	<input type="checkbox"/> left	<input type="checkbox"/> right	<input type="checkbox"/> reversible
	(view from air inlet)		
Motor performance:	power:	<input type="text"/>	W
	nominal torque:	<input type="text"/>	Nm
	nominal speed:	<input type="text"/>	rpm
Performance influencing application conditions:	operating pressure (at motor inlet):	<input type="text"/>	bar
	operation with lubricated air possible?	<input type="checkbox"/> yes	<input type="checkbox"/> no
	smallest opening cross-section of connection pieces and hoses?	<input type="text"/>	mm
External motor design:	<input type="checkbox"/> standard steel	<input type="checkbox"/> non-corrosive	<input type="checkbox"/> aluminium
	<input type="checkbox"/> plastics	<input type="checkbox"/> ceramics	
	other:	<input type="text"/>	
Drive spindle design:	drive shaft requirements:	<input type="text"/>	
	(e. g. keyed shafts, square end, hexagonal, collet, drill chuck taper, etc.)		
	required dimensions:	<input type="text"/>	
Motor fixture design:	mounting requirements: (bracket, flange, etc.)	<input type="text"/>	
	required dimensions:	<input type="text"/>	
Additional components:	<input type="checkbox"/> holding brake	<input type="checkbox"/> operational brake	
	gear box:	<input type="text"/>	
Price range:	<input type="text"/>		
Annual requirement:	<input type="text"/>		

DEPRAG

DEPRAG SCHULZ GMBH u. CO.

P.O. Box 1352, D-92203 Amberg, Germany
Kurfürstenring 12-18, D-92224 Amberg
Phone (09621) 371-0, Fax (09621) 371-120
www.deprag.com
info@deprag.de

CERTIFIED AS PER DIN EN ISO 9001
