



Screwdriving technology

Automation

Air motors

Air tools

DEPRAG

ADVANCED LINE

Stainless Steel Air Motors

from 20 W / 0.03 Hp up to 1.2 kW / 1.6 Hp

NEW MOTOR RANGE

High torque motors made from stainless steel:

Our ADVANCED LINE pneumatic motors are now available as high torque motors made from stainless steel. The ideal drive solution for e.g. agitators and industrial mixers.

non corrosive **ATEX conform** **oil-free** **sealed**
sterilisable **compact** **insensitive to cleaning solvents**

The ADVANCED LINE air motors are particularly suitable for use in the food industry, medical technology, underwater applications and the chemical industry.

All external parts (housing and spindle) of our ADVANCED LINE series are made from high quality non corrosive steel.

All air motors can be operated oil-free without special adaption and with only a 15 % reduction in power.

Our air motors are also available in an ATEX conform complete system with integrated holding brakes.

In addition our modular principle enables us to offer low cost customisations for your specific application!



conform system: air motor - holding brake - gear



PRODUCT SPECTRUM OVERVIEW: ADVANCED LINE AIR MOTORS

Stainless steel motors with integrated planetary gears



The vane motors of the ADVANCED LINE are particularly compact drive solutions for installation in either handheld machines or industrial systems. These top quality stainless steel motors are suitable for the chemical industry, for the paper industry, the pharmaceutical industry, medical technology and also for use in the food industry. The air motor is sealed, no dirt from the surrounding area can enter. It can also be operated oil-free.

Performance classes:

20 W	Page 4
30 W	Page 4
80 W	Page 6
120 W	Page 8
200 W	Page 10
300 W	Page 10
600 W	Page 16
900 W	Page 16
1.2 kW	Page 20

High torque stainless steel motors



The high torque motors of the ADVANCED LINE are small in size but provide extremely high output. Our high torque motors are also less apt to stall, the stalling torque for e.g. motor type 67-517 is 800 Nm. These drive solutions are particularly suitable for use in industrial agitators and mixers as used in the paint industry, food industry or pharmaceutical industry.

Performance classes:

285 W	Page 12
570 W	Page 18
860 W	Page 18

Stainless steel motors with integrated holding brake



Due to their size and design DEPRAG stainless steel motors with integrated holding brake are the optimal choice for use in any application where reliability plays an important role. The integrated holding brake can either be controlled using a separate control lead or via the motor exhaust. If pressure falls the brakes are automatically activated.

The big plus: This innovative complete system is also available with ATEX certification!

Performance classes:

200 W	Page 14
300 W	Page 14
1.2 kW	Page 22

ADVANTAGES OF ADVANCED LINE AIR MOTORS

LONG LIFE-SPAN

A wide product range of stainless steel motors, the use of DEPRAG high performance vanes as well as a specific surface coating on our materials all this ensures your motor's long life-span.



Airmotor - gear box - valve: a stainless steel system for the paper industry, sealed stainless steel motors, high performance vanes

SHORT DELIVERY TIMES

Due to our large amount of in-house production we are able to deliver quickly and flexibly at short notice, even when dealing with smaller quantities.

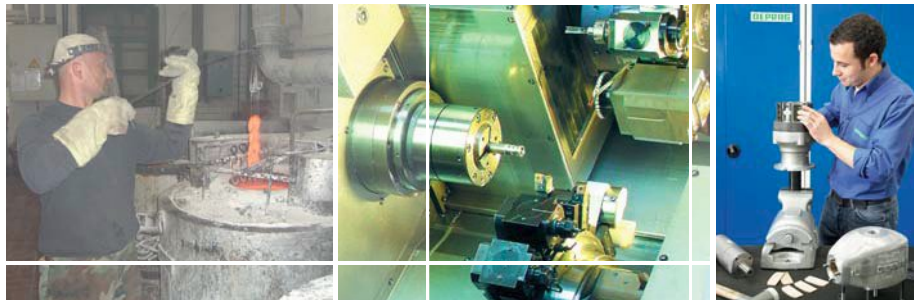

Large amount of in-house production, on-site salt bath heat treatment facility

APPLICATION CONSULTANCY

Our application engineers will gladly advise you in the selection of the most suitable drive for your application. If you would like to test or replace your existing drive we can check it for you in our innovative performance testing facility.



Performance testing facility, professional guidance from our engineers

WIDE VARIETY AND COMPREHENSIVE RANGE OF ACCESSORIES

Our standard programme is distinguished by its wide variety. All our stainless steel motors are also available with threaded spindle. Additionally due to our modular principle we are able to offer numerous variations to choose from. Do not hesitate to contact us if you have a specific mounting fixture request.

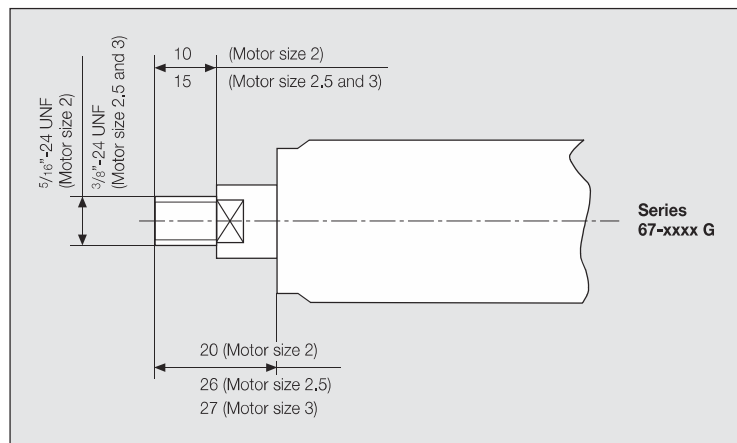

Individual customisation at an attractive price

570 W / 860 W ADVANCED LINE HIGH TORQUE AIR MOTOR

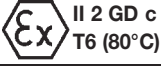
Motor size 6		reversible			
Series 67-	 Type	67-146	67-156	67-166	67-516
	part no.	444570 I	444570 K	444570 L	444570 M
Nominal-Power	W / HP	570 / 0.76	570 / 0.76	570 / 0.76	565 / 0.757
Nominal-Speed	rpm	75	55	37	20
Speed (idling)	rpm	150	110	74	40
Nominal-Torque	Nm / in.lbs	72 / 637.2	98 / 867.3	150 / 1327.5	265 / 2345.3
Start Torque min.	Nm / in.lbs	108 / 955.8	147 / 1301	225 / 1991.3	400 / 3540
Air Consumption	m ³ /min / cfm	0.85 / 30	0.85 / 30	0.85 / 30	0.85 / 30
Weight	kg / lbs	3.6 / 7.9	3.6 / 7.9	3.6 / 7.9	4.4 / 9.7
Hose I.D.	mm / in.	12 / 1/2	12 / 1/2	12 / 1/2	12 / 1/2

Performance data relate to an air pressure of 6 bar (85 PSI)

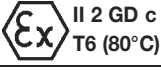
Motor size 7		reversible			
Series 67-	 Type	67-147	67-157	67-167	67-517
	part no.	440066 I	440066 K	440066 L	440066 M
Nominal-Power	W / HP	860 / 1.15	860 / 1.15	860 / 1.15	850 / 1.14
Nominal-Speed	rpm	75	55	35	20
Speed (idling)	rpm	150	110	70	40
Nominal-Torque	Nm / in.lbs	110 / 973.5	150 / 1327.5	225 / 1991.3	400 / 3540
Start Torque min.	Nm / in.lbs	160 / 1416	220 / 1947	335 / 2964.8	600 / 5310
Air Consumption	m ³ /min / cfm	1.4 / 49.4	1.4 / 49.4	1.4 / 49.4	1.4 / 49.4
Weight	kg / lbs	3.8 / 8.4	3.9 / 8.6	3.9 / 8.6	4.7 / 10.3
Hose I.D.	mm / in.	12 / 1/2	12 / 1/2	12 / 1/2	12 / 1/2

Performance data relate to an air pressure of 6 bar (85 PSI)

Allowable shaft loading see page 24.

Optional Equipment:	Motor size 6 / 7		
	Type 67-146 to 67-166 Type 67-147 to 67-167	Type 67-516 Type 67-517	
Flange necessary 4 cylinder-screws	part no. part no.	413462 823148 (8 pieces)*	413463 823545 (6 pieces)**
Bracket necessary 4 cylinder-screws	part no. part no.	4446172 823148 (8 pieces)*	4446173 823545 (6 pieces)**
Silencer: motor operates in one direction (right or left rotation)			
1 Hose nozzle	part no.	410540 (3/8")	
1 Silencer	part no.	802671 (3/8")	
1 Silencer	part no.	802666 (1/2")	
Silencer: motor is reversible (right and left rotation)			
2 Hose nozzles	part no.	410540 (3/8")	
1 Silencer	part no.	802666 (1/2")	
		Motor size 6	Motor size 7
Maintenance unit with lubricator* Connection thread	part no.	820455 A G 1/2	821608 A G 3/4
Maintenance unit without lubricator* Connection thread	part no.	822409 A G 1/2	826982 A G 3/4
Replacement part set consisting of: vanes, sealant rings, o-rings and silencers	part no. part no.	444787 D/for type 67-146 to 67-166 444787 E/for type 67-516	444919 C/for type 67-147 to 67-167 444919 D/for type 67-517

*) Maintenance unit consists of pressure regulator valve, filter and optionally with or without lubricator

***) no. of cylinder screws required

Our standard maintenance units are ATEX conform. Please contact us if this is a requirement.

Of course you can also purchase individual replacement parts from us.

Further notes for soundproofing see page 25.

Motor size 6 and 7 High torque stainless steel motors

Series 67-

reversible

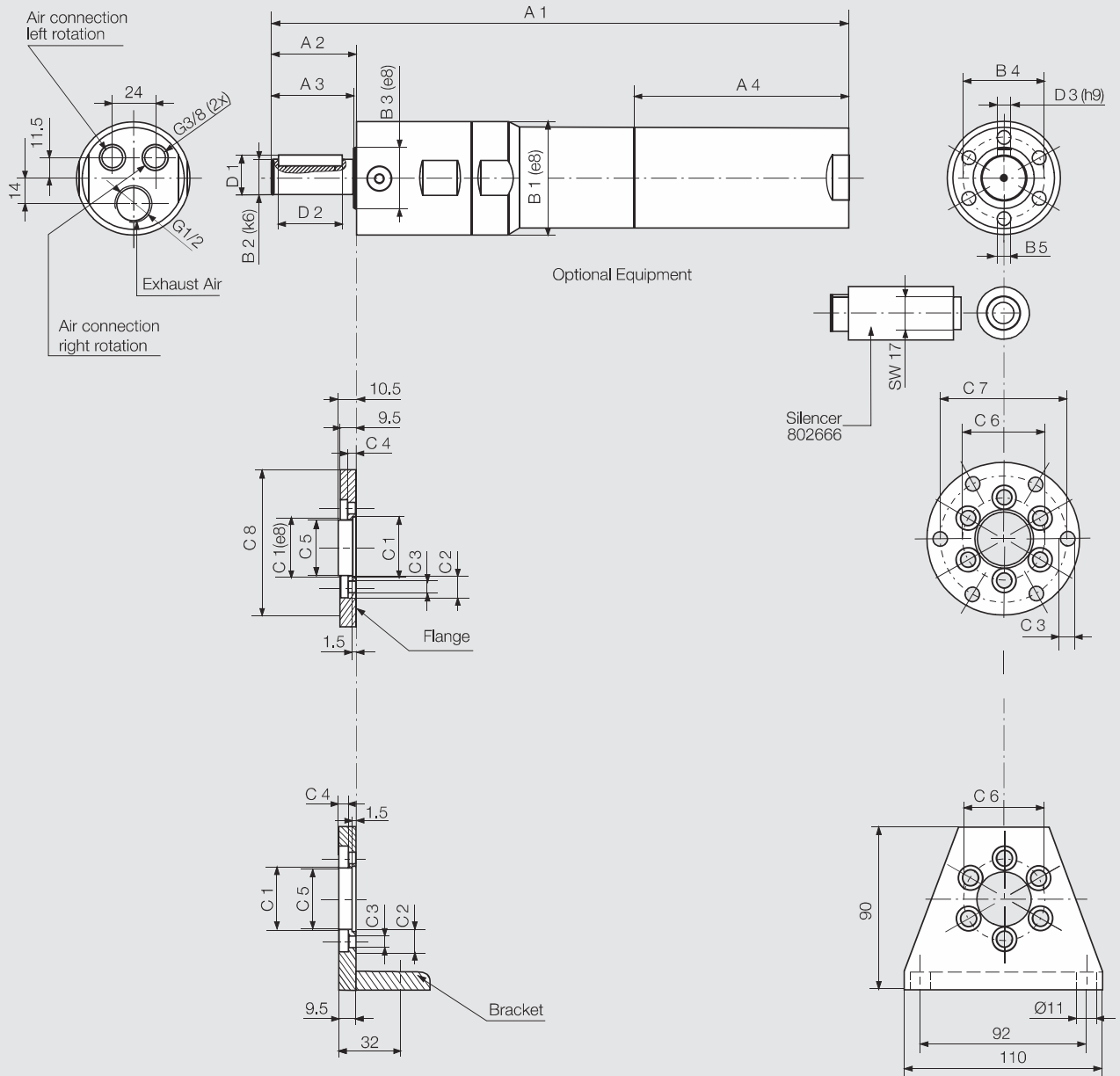

p444338

Motor size	Series 67- Type			Dimensions of Motor (mm)																			
				A1	A2	A3	A4	B1	B2	B3	B4	B5	C1	C2	C3	C4	C5	C6	C7	C8	D1	D2	D3
6	67-146	67-156	67-166	283.4	44	42	98.5	56 e8	19	35	48	M6	35	11	6.6	4.4	32	48	70	85	21.5	32	6
	67-516			347	47	45	98.5	63 h8	24	34	45	M8	34	13.1	8.4	5.4	30	45	79	95	27	32	8

Motor size	Series 67- Type			Dimensions of Motor (mm)																			
				A1	A2	A3	A4	B1	B2	B3	B4	B5	C1	C2	C3	C4	C5	C6	C7	C8	D1	D2	D3
7	67-147	67-157	67-167	303.4	44	42	118.5	56 e8	19	35	48	M6	35	11	6.6	4.4	32	48	70	85	21.5	32	6
	67-517			320.1	47	45	118.5	63 h8	24	34	45	M8	34	13.1	8.4	5.4	30	45	79	95	27	32	8

Maximum allowable shaft load of the drive shaft

flattened shaft
Motor size 0 and 1

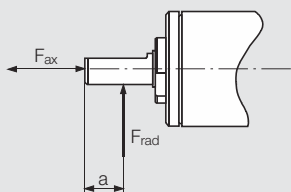

parallel key shaft
Motor size 2 to 8

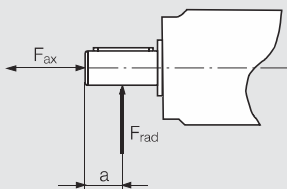

threaded shaft

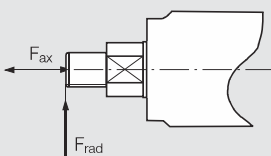

drill chuck

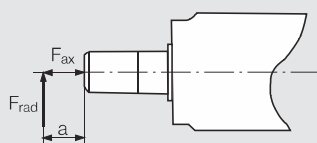

Motors with flattened shaft

Motor size	part no.		Fax [N]	Frad [N]	a [mm]
MG 0	445115 D, E		140	180	6
MG 0	445462 E		140	180	6
MG 1	445127 A-D		200	220	7

Allowable force for 10 million spindle rotations with 90 % survival probability of bearing.

Motors with parallel key shaft

Motor size	part no.	part no. with holding brake	Fax [N]	Frad [N]	a [mm]
MG 2	444550 A-H		380	160	9
MG 2.5	444500 A-H	445760 A-F	570	720	12
MG 2.5	445184 A, B		1100	1200	22
MG 3	444560 A-D	445762 A-D	570	1130	14
MG 3	444560 E-H, K	445762 E, F	790	1070	15
MG 3	445183 A, B		1100	1200	22
MG 3	444560 I, L, M		1500	3500	21
MG 3	444560 N, O		1500	3500	20
MG 6	444570 A-D, H		1110	1300	15
MG 6	444570 E-G		1130	2090	18
MG 6	444570 I, K, L		1500	3500	21
MG 6	444570 M		1500	3500	22.5
MG 7	440066 A-D, H		1110	1300	15
MG 7	440066 E-F		1130	2090	18
MG 7	440066 I, K, L		1500	3500	21
MG 7	440066 M		1500	3500	22.5
MG 8	444580 A-C	440097 A-C, 4400971A-C	2330	2260	18
MG 8	444580 D-F	440097 D-E, 4400971D-E	2330	2700	30

Allowable force for 10 million spindle rotations with 90 % survival probability of bearing.

Motors with threaded spindle

Motor size	part no.		Fax [N]	Frad [N]	a [mm]
MG 2	444950 A-H		380	110	0
MG 2.5	445314 A-L		570	450	0
MG 3	445682 A-D		570	860	0
MG 3	445682 E-H		790	820	0

Allowable force for 10 million spindle rotations with 90 % survival probability of bearing.

Motors with drill chuck

Motor size	part no.		Fax [N]	Frad [N]	a [mm]
MG 6	445353 B-D, H		1100	150	80
MG 6	445353 E-G		1100	265	80

Allowable force for 10 million spindle rotations with 90 % survival probability of bearing.

TECHNICAL DATA

Noise level of the motors

Noise level for motors of the series 67 - without or with silencer (see optional equipment)			
for Motor size	Noise level dB (A) without silencer	Noise level dB (A) with silencer	part no. silencer
0	98	85	811355
1	95	85	823236
2	99	92	823236
2.5	100	82	802675 / 802673
3	103	91	802673
6	104	94	802671 / 802666
7	106	88	802671 / 802666
8	108	95	802666 / 822086

Optional Silencer sets for further reduction of the noise level

Silencer sets for motors of the build series 67 - Attachment for only one rotation direction (clockwise or anticlockwise rotation)			
for Motor size	part no.	Hose length mm	Noise level ca. dB (A)
1	446354 B	500	71
2	440015 B	500	70
2.5	440016 B	500	71
3	440018 B	500	70
6	440019 B	500	76
7	440019 B	500	79
8	440020 B	500	87

Silencer sets for motors of the build series 67 - Attachment adjustable (clockwise and anticlockwise rotation)			
for Motor size	part no.	Hose length mm	Noise level ca. dB (A)
1	446354 A	500	71
2	440015 A	500	70
2.5	440016 A	500	71
3	440018 A	500	70
6	440019 A	500	76
7	440019 A	500	79
8	440020 A	500	87

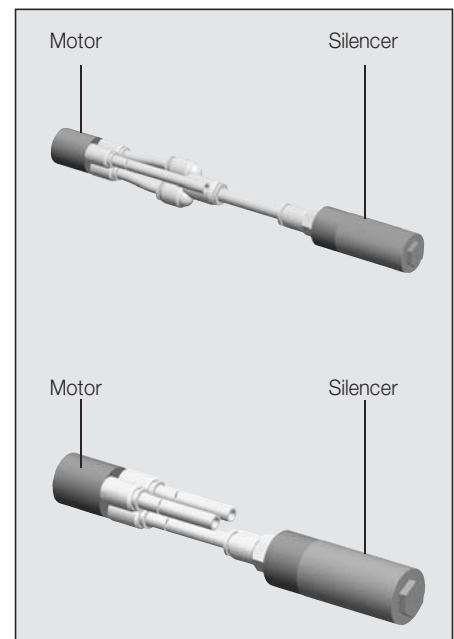

Use in potentially explosive environments



The correspondingly marked motors are suitable for use in potentially explosive environments.

Speed standard values (rpm) for HSS spiral drills

Cutting Speed	35 m/min (115 ft./min)	28 m/min (90 ft./min)	25 m/min (80 ft./min)	14 m/min (45 ft./min)	11 m/min (35 ft./min)	7 m/min (23 ft./min)	22 m/min (70 ft./min)	12 m/min (40 ft./min)	50 m/min (165 ft./min)	90 m/min (300 ft./min)	165 m/min (540 ft./min)	210 m/min (690 ft./min)
Drill dia. mm/in.	up to 500 N/mm ² (30 long tons/sq. in.)	Carbon steel		Alloy steel		Stainless steel	Cast-Iron		Copper Bronze Brass	Lightweight-Metal		Magnesium-Alloy ²⁾
		500 - 700 N/mm ² (30 - 45 long tons/sq. in.)	above 700 N/mm ² (45 long tons/sq. in.)	700 - 900 N/mm ² (45 - 55 long tons/sq. in.)	900 - 1100 N/mm ² (55 - 70 long tons/sq. in.)		up to 180 N/mm ² (10 long tons/sq. in.)	above 180 N/mm ² (10 long tons/sq. in.)		common alloy mild brass ¹⁾	hard	
1/0.04	11000	8800	7800	4400	3400	2200	7000	3800	16000	28000	52000	66000
2 ⁵ /64	5500	4400	3900	2200	1700	1100	3500	1900	8000	14000	26000	33000
3 ¹ /8	3700	3000	2600	1500	1100	730	2300	1300	5300	9000	17300	22000
4 ⁵ /32	2800	2200	2000	1100	850	550	1700	950	4000	7000	13000	16500
5 ¹³ /64	2200	1800	1600	880	680	440	1400	760	3200	5600	10400	13200
6 ¹⁵ /64	1900	1500	1300	735	570	365	1200	630	2700	4800	8700	11000
7 ⁹ /32	1600	1300	1100	630	485	315	1000	540	2300	4000	7400	9400
8 ⁵ /16	1400	1100	975	550	425	275	875	475	2000	3500	6500	8300
9 ²³ /64	1200	975	865	490	380	245	780	420	1800	3100	5800	7400
10 ²⁵ /64	1100	880	780	440	340	220	700	380	1600	2800	5200	6600

1) Speed for machining of thermoset plastics, laminates and hard laminates, however instead of the HSS-drills we recommend high-speed steel drills maded with hard-metal K 10

2) for thermoplastics use approx. double the values

The layout of your air motor:

Calculating the motor power

$$P = \frac{M \times n}{9550}$$

P = Power Output in kW

M = Nominal Torque in Nm

n = Nominal Speed in rpm

The optimal working range of an air motor is close to the nominal speed. If you need lower speeds than are mentioned in the catalogue you can reduce the speed by throttling the exhaust air with only a slight loss of power. By throttling the supply air or decreasing the operating pressure the speed, torque and power are reduced.

All performance data of the DEPRAG air motors is based on operating pressure of 6 bar and the opening cross-section mentioned in the motor data. If your application conditions are different from this then you will find a comprehensive guide to the layout of our motors in brochure D 6000 E.

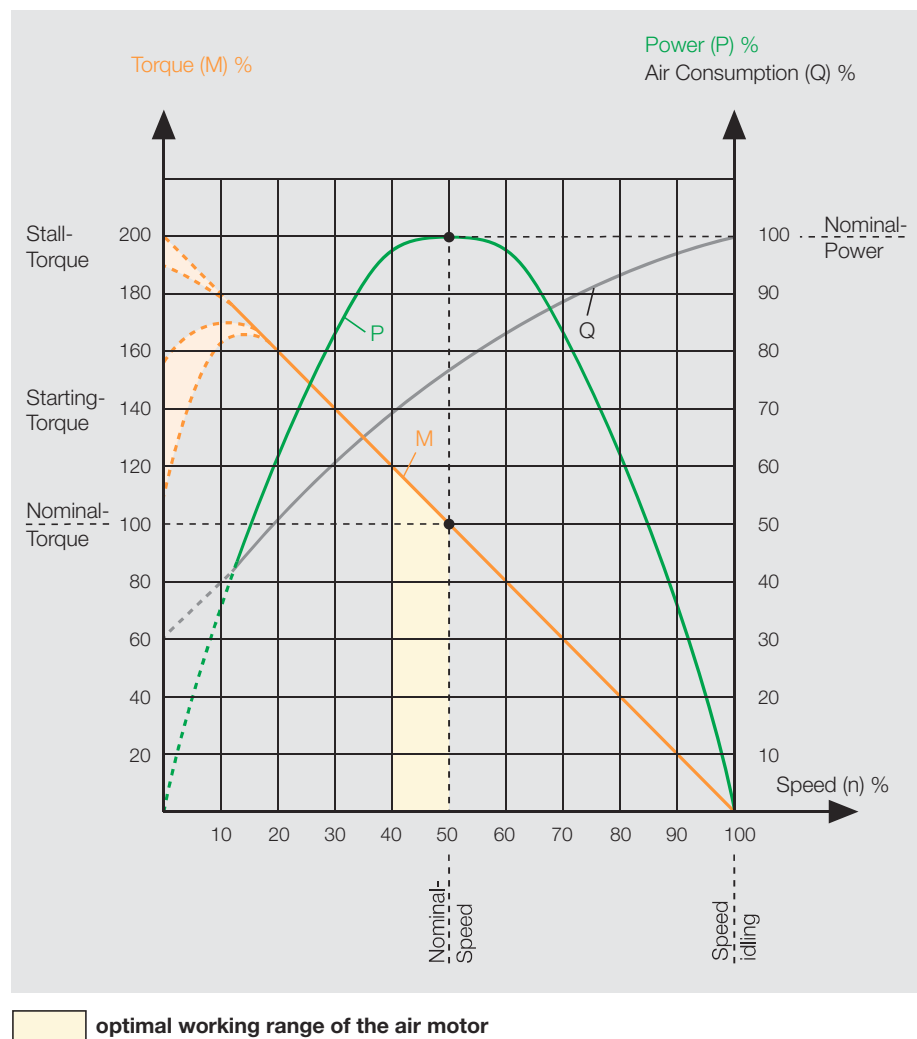

Do you need support in selecting the right drive system?

Tell us your operational conditions and our application consultants will be happy to help:

Application:	<input type="text"/>		
In what kind of environment will the motor be installed?	ATEX requirement / explosion safety?	<input type="checkbox"/> yes	<input type="checkbox"/> no
	if yes, which safety class:	<input type="text"/>	
	food industry conformity?	<input type="checkbox"/> yes	<input type="checkbox"/> no
	sterilisable?	<input type="checkbox"/> yes	<input type="checkbox"/> no
	acid resistant?	<input type="checkbox"/> yes	<input type="checkbox"/> no
	steam resistant?	<input type="checkbox"/> yes	<input type="checkbox"/> no
Application conditions:	constant operation (24 hrs, non-stop)	<input type="checkbox"/> yes	<input type="checkbox"/> no
	duty cycle in hrs/day:	<input type="text"/>	
	days/year:	<input type="text"/>	
	cycle time (s):	<input type="text"/>	
	motor loaded to stall?	<input type="checkbox"/> yes	<input type="checkbox"/> no
	self-locking?	<input type="checkbox"/> yes	<input type="checkbox"/> no
Required turn direction:	<input type="checkbox"/> left	<input type="checkbox"/> right	<input type="checkbox"/> reversible
	(view from air inlet)		
Motor performance:	power:	<input type="text"/>	W
	nominal torque:	<input type="text"/>	Nm
	nominal speed:	<input type="text"/>	rpm
Performance influencing application conditions:	operating pressure (at motor inlet):	<input type="text"/>	bar
	operation with lubricated air possible?	<input type="checkbox"/> yes	<input type="checkbox"/> no
	smallest opening cross-section of connection pieces and hoses?	<input type="text"/>	mm
External motor design:	<input type="checkbox"/> standard steel	<input type="checkbox"/> non-corrosive	<input type="checkbox"/> aluminium
	<input type="checkbox"/> plastics	<input type="checkbox"/> ceramics	
	other:	<input type="text"/>	
Drive spindle design:	drive shaft requirements:	<input type="text"/>	
	(e. g. keyed shafts, square end, hexagonal, collet, drill chuck taper, etc.)		
	required dimensions:	<input type="text"/>	
Motor fixture design:	mounting requirements: (bracket, flange, etc.)	<input type="text"/>	
	required dimensions:	<input type="text"/>	
Additional components:	<input type="checkbox"/> holding brake	<input type="checkbox"/> operational brake	
	gear box:	<input type="text"/>	
Price range:	<input type="text"/>		
Annual requirement:	<input type="text"/>		

DEPRAG

DEPRAG SCHULZ GMBH u. CO.

P.O. Box 1352, D-92203 Amberg, Germany
Kurfürstenring 12-18, D-92224 Amberg
Phone (09621) 371-0, Fax (09621) 371-120
www.deprag.com
info@deprag.de

CERTIFIED AS PER DIN EN ISO 9001
